

EQUIPMENT SHEET

AIR AND MIXED GAS DIVE SYSTEM
SPREAD 38

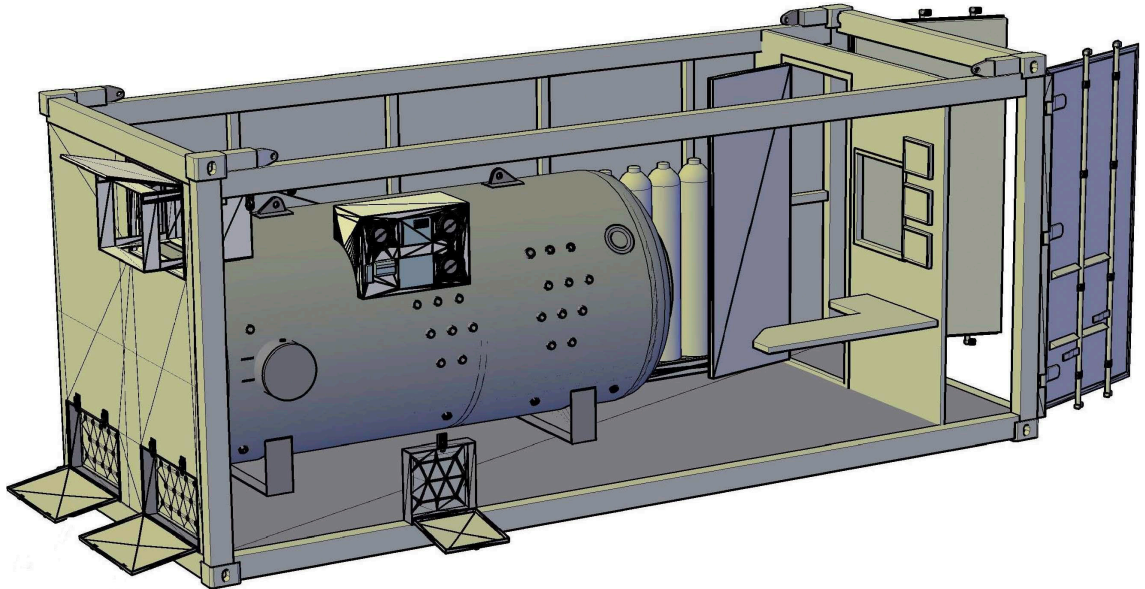

A

FEATURES

Modular Air Dive System 018 is an Air Diving spread that comes in two 20 ft containers with one Launch and Recovery System (LARS), 2 x 130 m diver umbilicals, Air and O₂ quads. The Deck Decompression Chamber (DDC) and Dive Control are located in one 20 ft container. The workshop, compressors, hydraulic power pack and spares are located in the second 20 ft container. The system comes with a Hydraulic Power Pack with 120 m hose for subsea tools.

This Air Diving system has been designed to ensure maximum flexibility to perform work across all key subsea markets. This system is compact and is optimized for installation on-board offshore rigs, barges and dive support vessels.

This Air Diving system features a unique video management system that delivers superior operational output of performance in high definition available on demand to our clients. This air diving system twin

20 ft DNV containerized units have been classed to the standards of DNV 2.7-1 capability for open sea & offshore lifting to increase the availability and flexibility of this Air Diving System.

IMCA DO23 compliant.

Designed for fast mobilisation/demobilisation, plug and play units.

Separate 20 ft Dive control and chamber control container.

Separate 20 ft workshop/compressor and spares container (optional 10 ft container).

DIVE CONTROL

Dive control for 3 divers

CCTV system for diver hat camera, ROV and deck

High intensity diver hat light c/w dimmer

HD Video distribution (client, roV, deck, bridge, survey) (optional)

Round Robin communication system

Communication system Deck- Bridge hard wired (optional)

Welding/Burning control

DP alarm indicators (optional)

Durable environment (temperature) control

Diving medical supplies and control kits (DMAC)

PRESSURE CHAMBER

Chamber 60 inch, twin compartment

Design code PD5500: 2000 CAT.2

Build as per class Lloyd's Register



WORKSHOP MACHINERY

Power distribution panel 380 - 440 VAC input

L&W - 450e High Pressure compressor

Quincy 63CFM Low Pressure compressor

Hydraulic power pack and tooling

DIMENSION/POWER REQUIREMENTS

Power requirement 380 - 440 VAC @ 50/60 Hz

Dive control container L - 6.06 m, W - 2.44 m, H - 2.59 m

Machinery container L - 6.06 m, W - 2.44 m, H - 2.59 m

Deployment stage (LARs) L - 3.60 m, W - 2.40 m, H - 3.62 m